

# Engineering Drawing Principles L-7



विद्यया जीयतामृतं ज्ञानम्  
**IITM Gwalior**

## Orthographic Projection

When the projectors are parallel to each other and also perpendicular to the plane, the projection is called *orthographic projection*.

Imagine that a person looks at the block from a theoretically infinite distance, so that the rays of sight from his eyes are parallel to one another and perpendicular to the front surface *F*. The view of this block will be the shaded figure, showing the front surface of the object in its true shape and proportion.

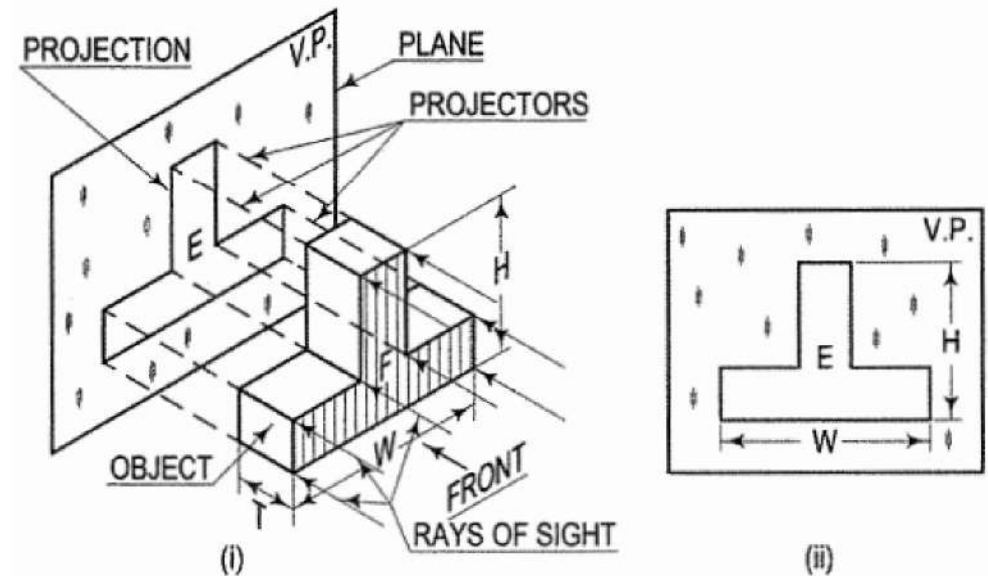

## Orthographic Projection

The points on VP at which they meet the plane are joined in proper sequence, the resulting figure (marked f) will also be exactly similar to the front surface and this is known as an *elevation* or *front-view*.

The projection on the H.P. shows the top surfaces of the block. If a person looks at the block from above, he will obtain the same view as the figure *P* and is known as a *plan* or *top-view*.

One of the planes is now rotated or turned around on the hinges so that it lies in extension of the other plane.

This can be done in *two* ways:

- (i) by turning the V.P. in direction of arrows *A*
- (ii) by turning the H.P. in direction of arrows *B*

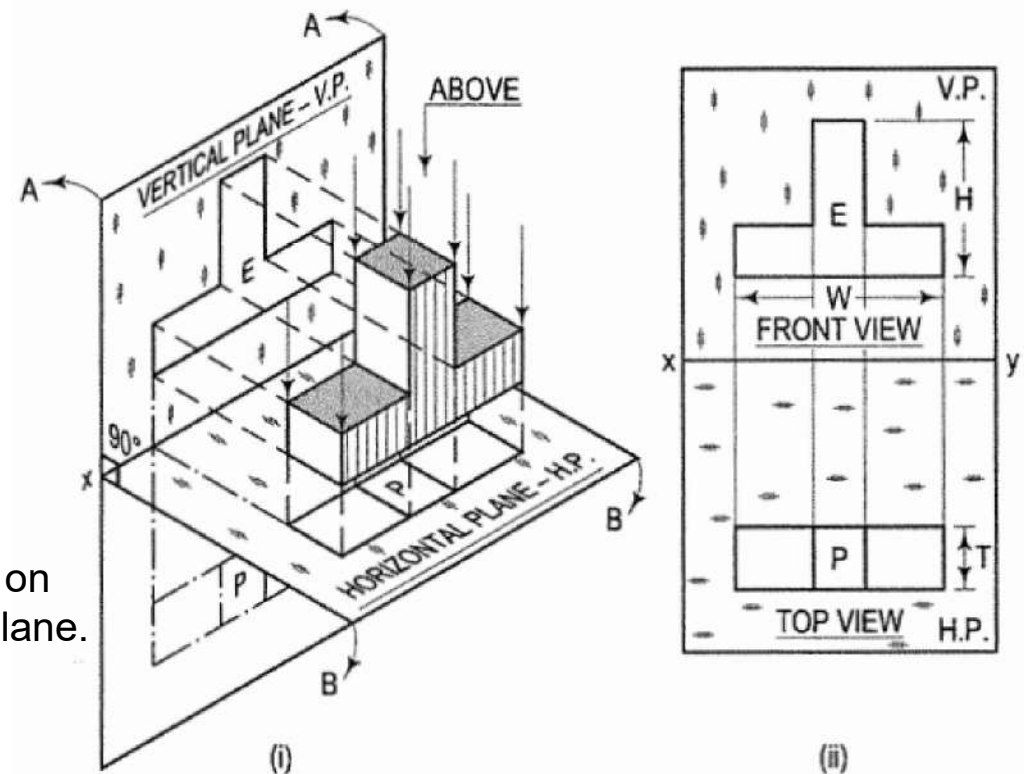

# Orthographic Projection

## Planes of Projection and Four Quadrants

- The two planes employed for the purpose of orthographic projections are called *reference planes* or *principal planes of projection*.
- They intersect each other at right angles.
- The *vertical plane* of projection (in front of the observer) is usually denoted by the letters V.P. It is often called the *frontal plane* and denoted by the letters F.P.
- The other plane is the *horizontal plane* of projection known as the H.P. The line in which they intersect is termed the *reference line* and is denoted by the letters *xy*.
- The projection on the V.P. is called the *front view* or the *elevation* of the object.
- The projection on the H.P. is called the *top view* or plan

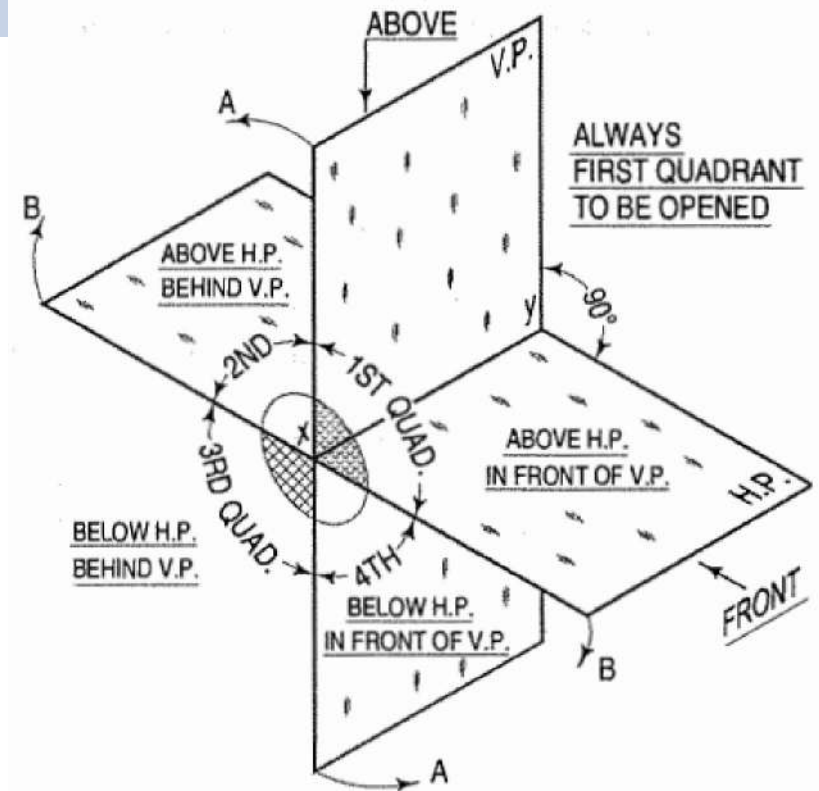

# Orthographic Projection

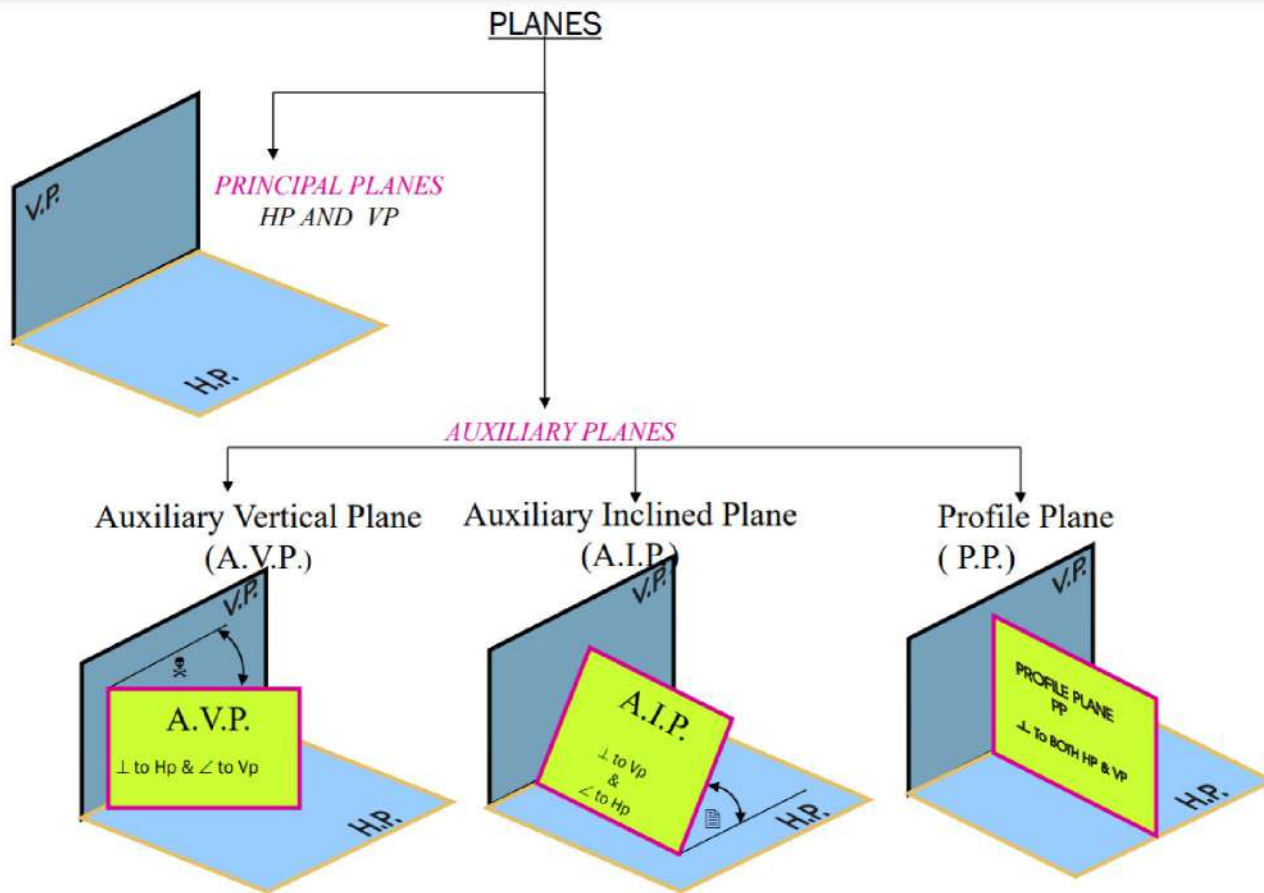

## Orthographic Projection: First Angle Projection

The object is assumed to be situated in front of the V.P. and above the H.P. i.e. in the first quadrant and then projected it on these planes. This method of projection is known as *first-angle projection method*. The object lies between the observer and the plane of projection.

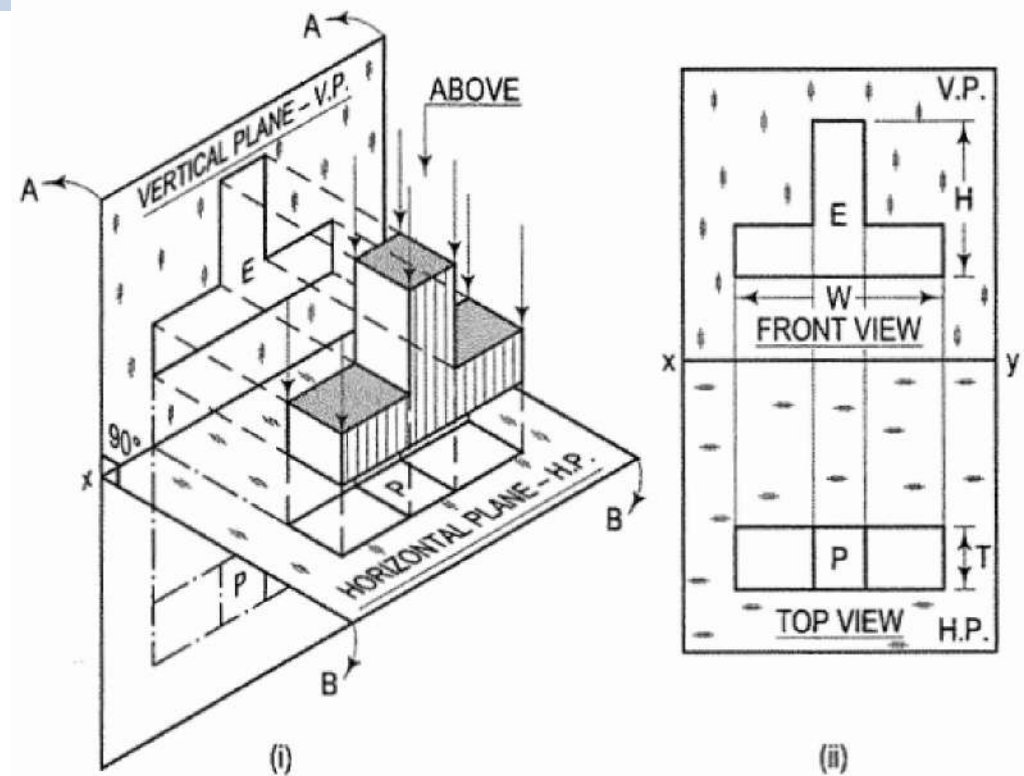

## PATTERN OF PLANES & VIEWS (First Angle Method)

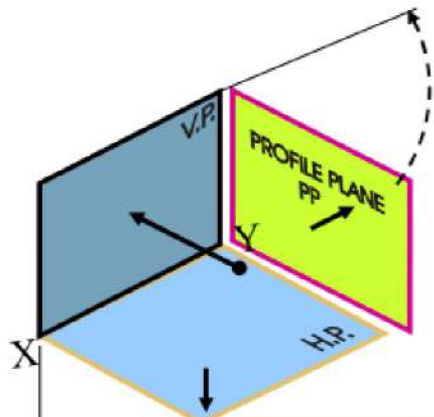

THIS IS A PICTORIAL SET-UP OF ALL THREE PLANES. ARROW DIRECTION IS A NORMAL WAY OF OBSERVING THE OBJECT. BUT IN THIS DIRECTION ONLY VP AND A VIEW ON IT (FV) CAN BE SEEN. THE OTHER PLANES AND VIEWS ON THOSE CAN NOT BE SEEN.

### PROCEDURE TO SOLVE ABOVE PROBLEM:-

TO MAKE THOSE PLANES ALSO VISIBLE FROM THE ARROW DIRECTION,  
 A) HP IS ROTATED 90° DOWNWARD  
 B) PP, 90° IN RIGHT SIDE DIRECTION.  
 THIS WAY BOTH PLANES ARE BROUGHT IN THE SAME PLANE CONTAINING VP.

Click to view Animation

On clicking the button if a warning comes please click YES to continue, this program is safe for your pc.

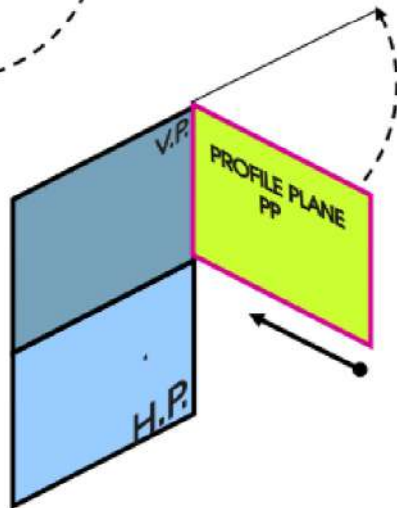

HP IS ROTATED DOWNWARD 90° AND BROUGHT IN THE PLANE OF VP.

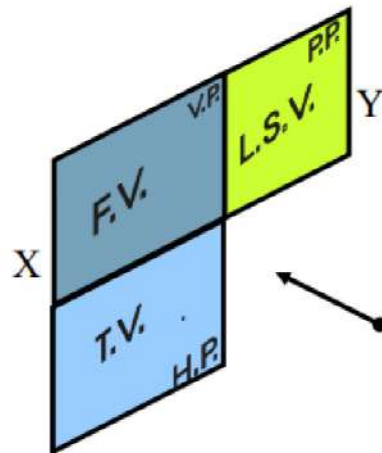

PP IS ROTATED IN RIGHT SIDE 90° AND BROUGHT IN THE PLANE OF VP.

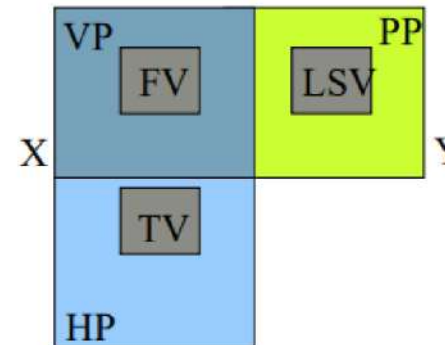

ACTUAL PATTERN OF PLANES & VIEWS OF ORTHOGRAPHIC PROJECTIONS DRAWN IN FIRST ANGLE METHOD OF PROJECTIONS

# Orthographic Projection

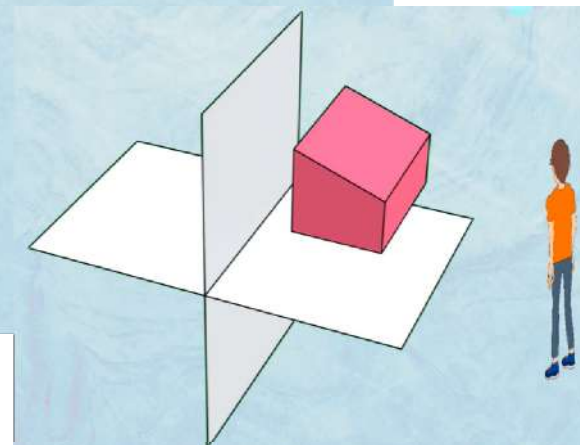
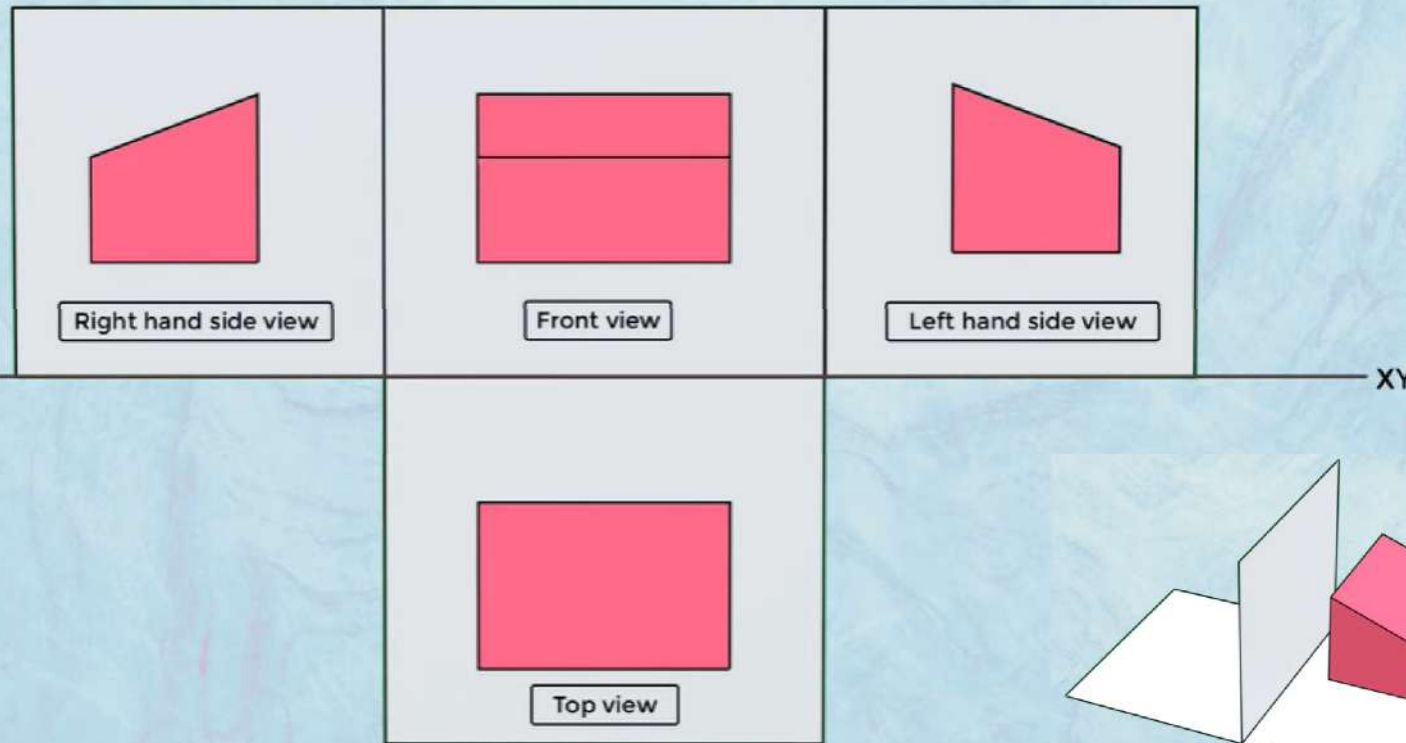

## Orthographic Projection: Third Angle Projection

- In this method of projection, the object is assumed to be situated in the third quadrant.
- The planes of projection are assumed to be transparent. They lie between the object and the observer.
- When the observer views the object from the front, the rays of sight intersect the V.P. The figure formed by joining the points of intersection in correct sequence is the front view of the object.
- The top view is obtained in a similar manner by looking from above. When the two planes are brought in line with each other.

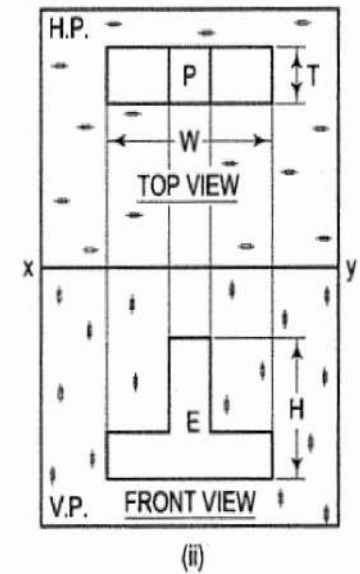
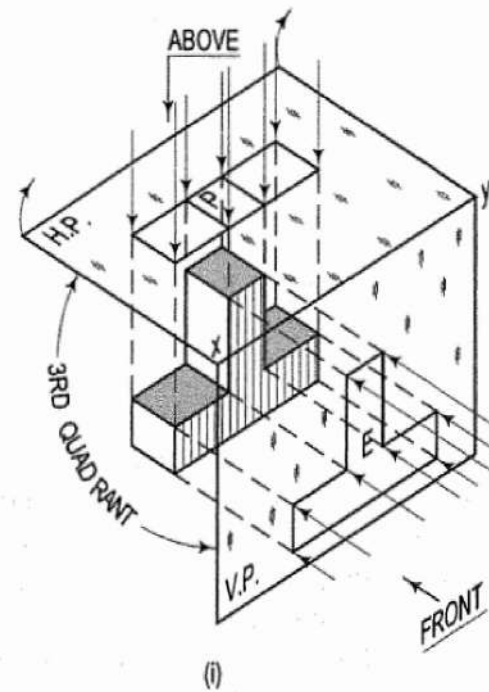

# Orthographic Projection

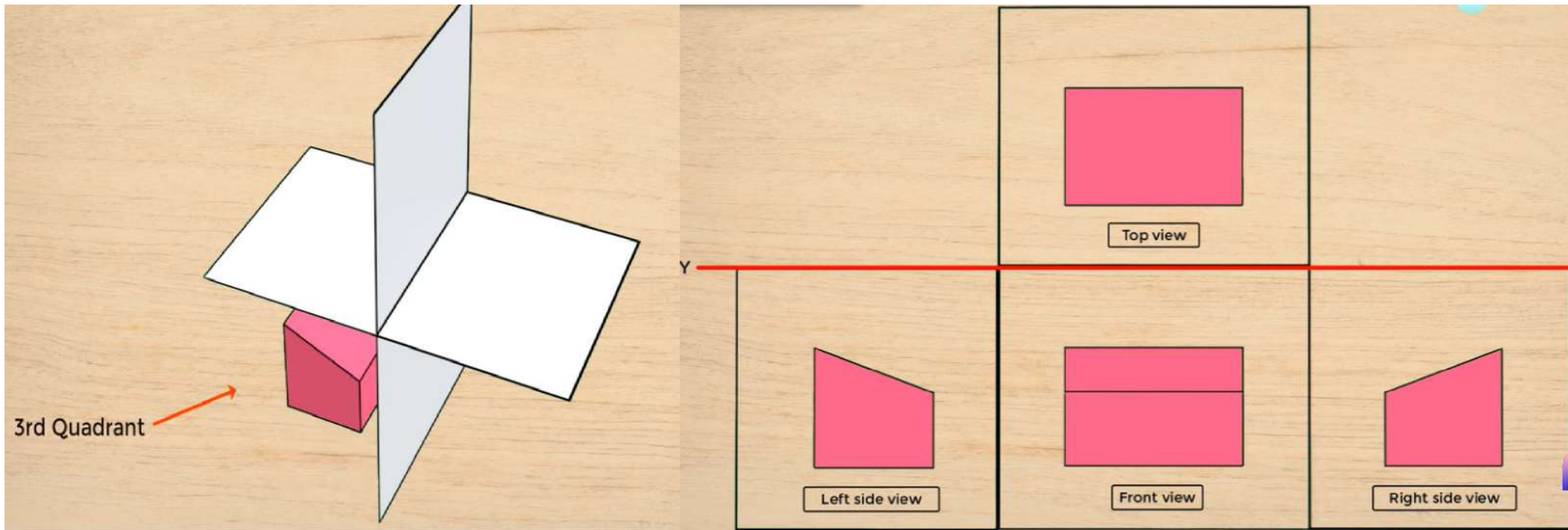

# Orthographic Projection

No.	First-angle projection method	Third-angle projection method
1.	The object is kept in the <i>first quadrant</i> .	The object is assumed to be kept in the <i>third quadrant</i> .
2.	The object lies between the observer and the plane of projection.	The plane of projection lies between the observer and the object.
3.	The plane of projection is assumed to be non-transparent.	The plane of projection is assumed to be <i>transparent</i> .
4.	In this method, when the views are drawn in their relative positions, the <i>plan</i> comes <i>below</i> the <i>elevation</i> , the view of the object as observed from the <i>left-side</i> is drawn to the <i>right of elevation</i> .	In this method, when the views are drawn in their relative positions, the <i>plan</i> , comes <i>above</i> the <i>elevation</i> , <i>left hand side view</i> is drawn to the <i>left hand side of the elevation</i> .
5.	This method of projection is now recommended by the "Bureau of Indian Standards" from 1991.	This method of projection is used in U.S.A. and also in other countries.

## 1. First angle system

- European countries
- ISO standard

## 2. Third angle system

- Canada, USA, Japan, Thailand

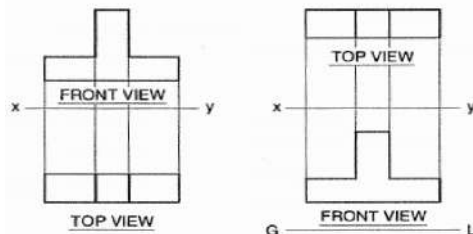
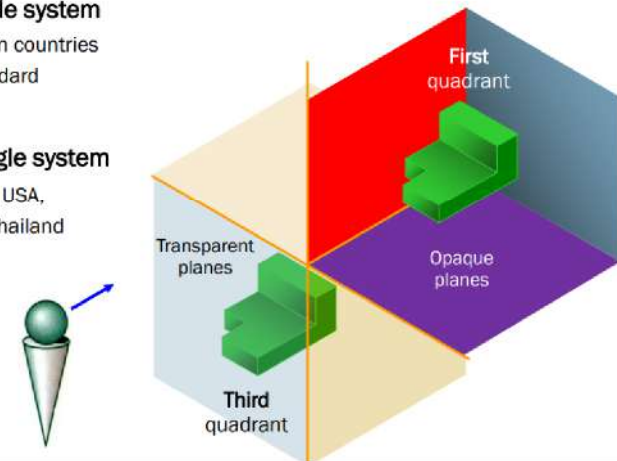

# Orthographic Projection

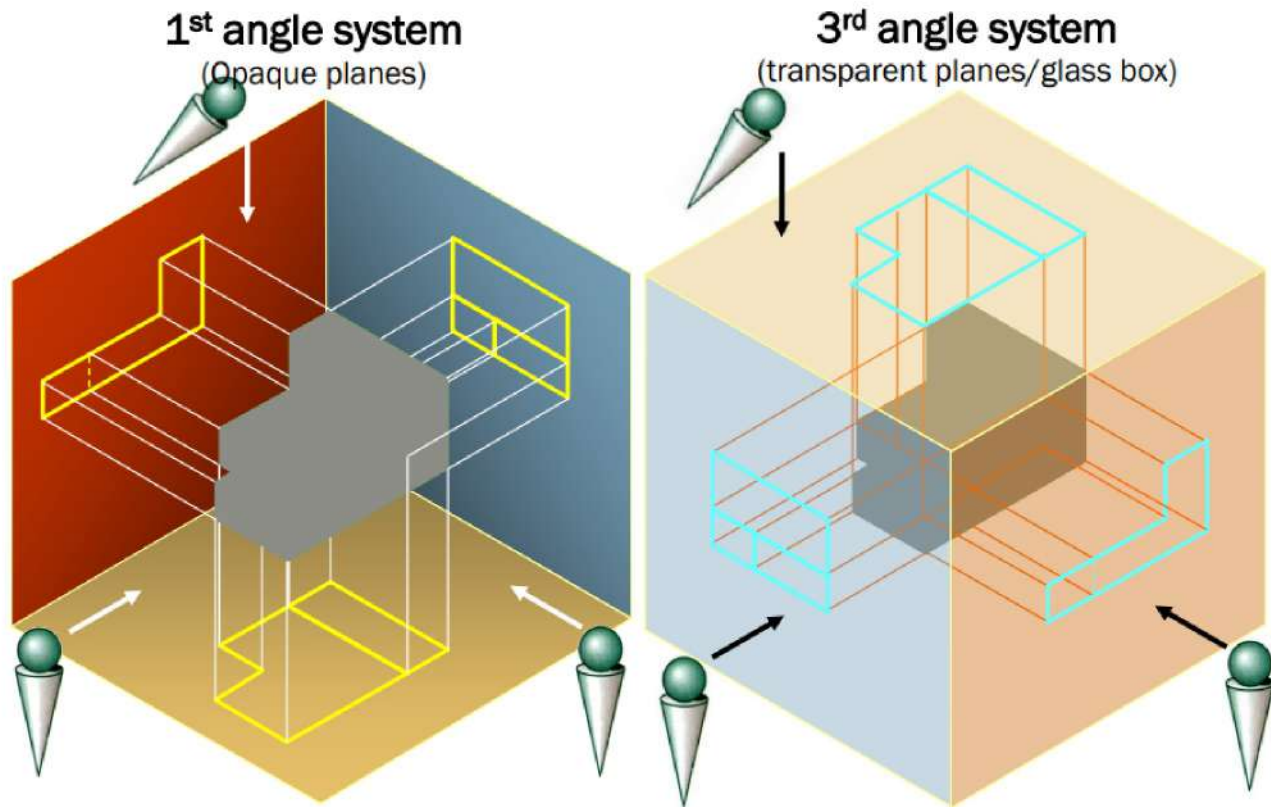

# Orthographic Projection

## Orthographic views

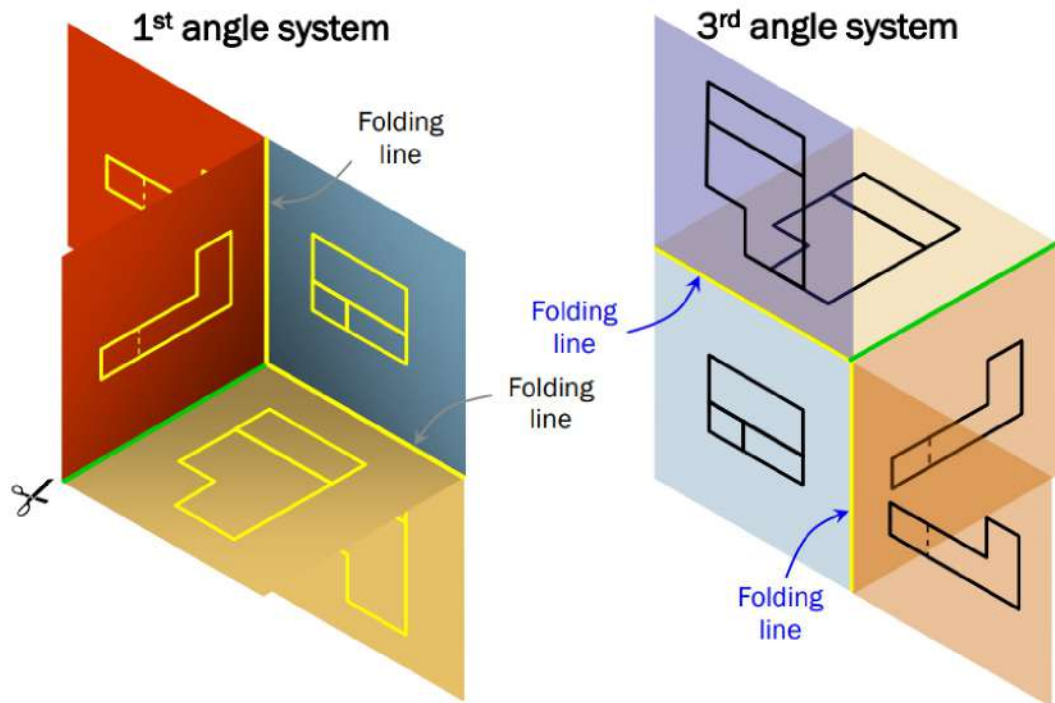

## Views arrangement

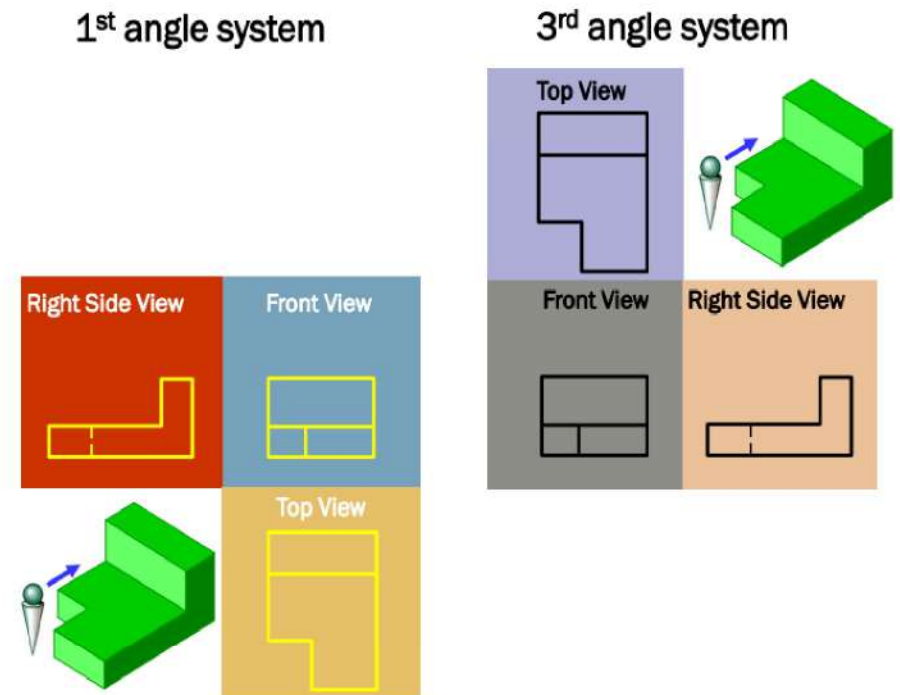

FIRST ANGLE PROJECTION METHOD

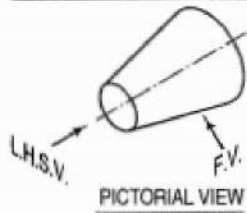

THIRD ANGLE PROJECTION METHOD

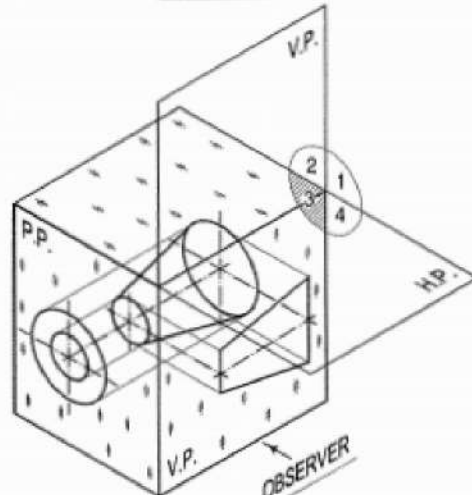
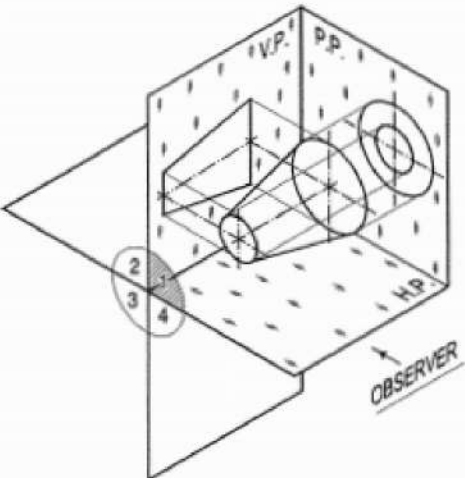
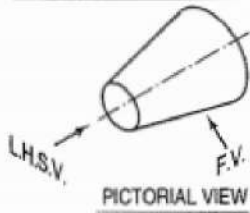

FIRST ANGLE PROJECTION



RELATION BETWEEN OBSERVER, OBJECT AND P.P.

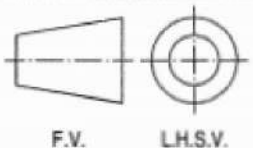

IDENTIFYING GRAPHICAL SYMBOL OF FIRST ANGLE PROJECTION

THIRD ANGLE PROJECTION

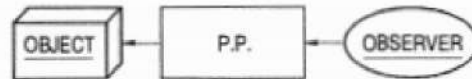

RELATION BETWEEN OBSERVER, OBJECT AND P.P.

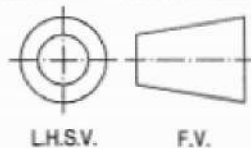

IDENTIFYING GRAPHICAL SYMBOL OF THIRD ANGLE PROJECTION



**Six views** of an Object: There are *three* important elements of this projection system, namely

- (a) an object
- (b) plane of projection
- (c) an observer

Very often, two views are not sufficient to describe an object completely. The planes of projection being imaginary, following six views are obtained:

- (1) Front view (FV)
- (2) Top view (TV)
- (3) Left hand side view (LHV)
- (4) Right hand side view (RHV)
- (5) Back view
- (6) Bottom view

# Projection symbols

1<sup>st</sup> angle system

3<sup>rd</sup> angle system

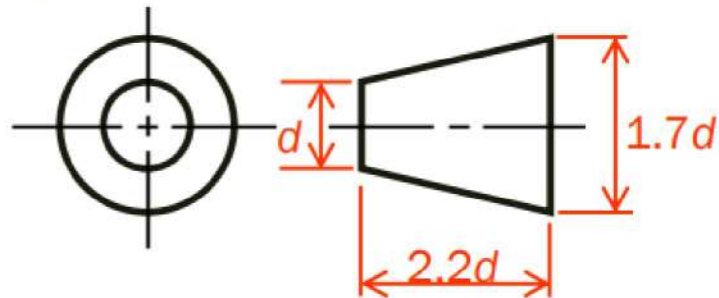
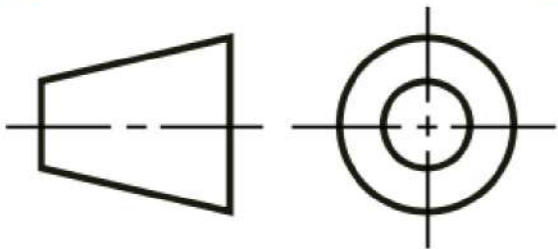
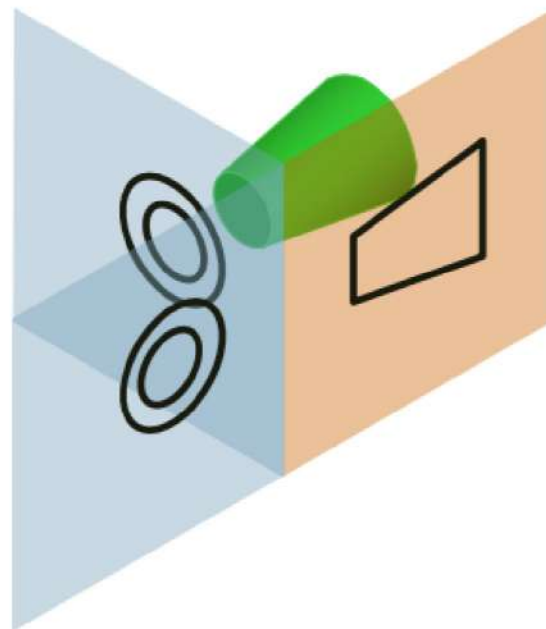
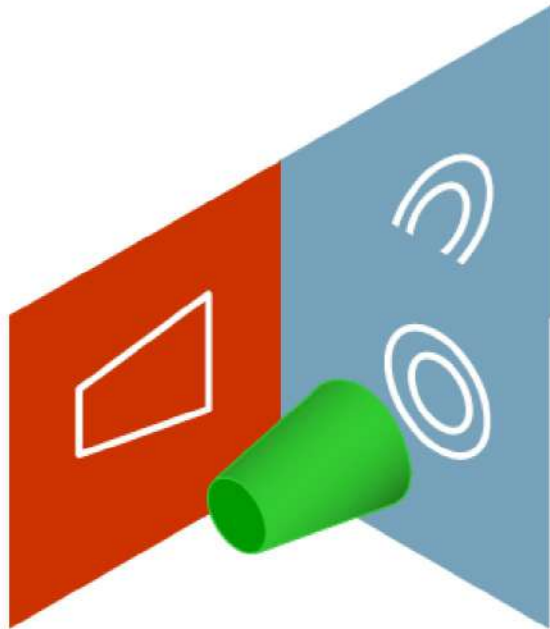

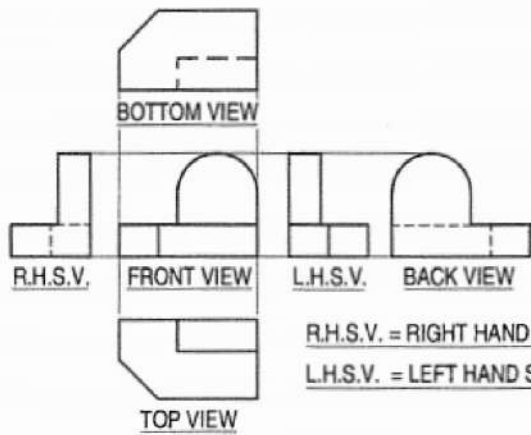
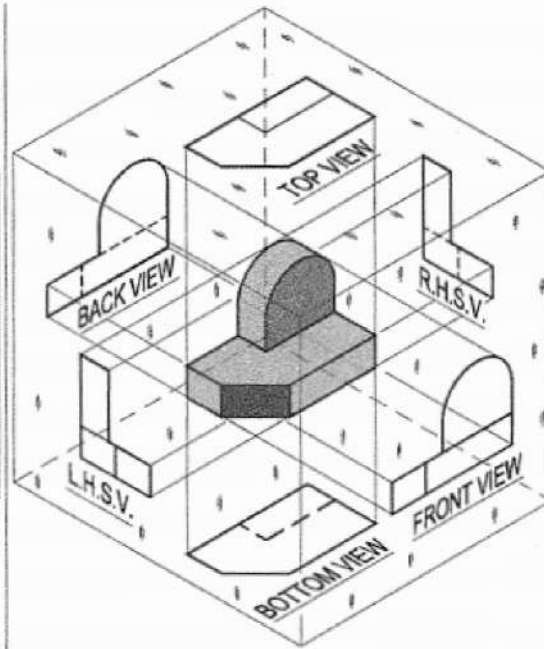
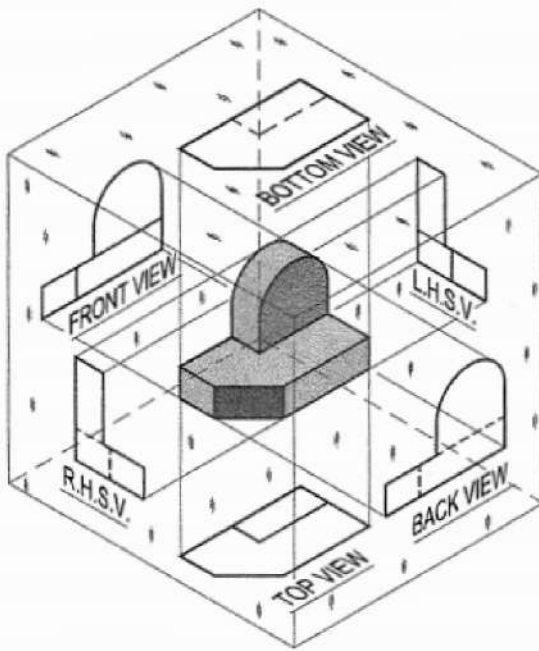

R.H.S.V. = RIGHT HAND SIDE VIEW  
L.H.S.V. = LEFT HAND SIDE VIEW

FIRST ANGLE PROJECTION

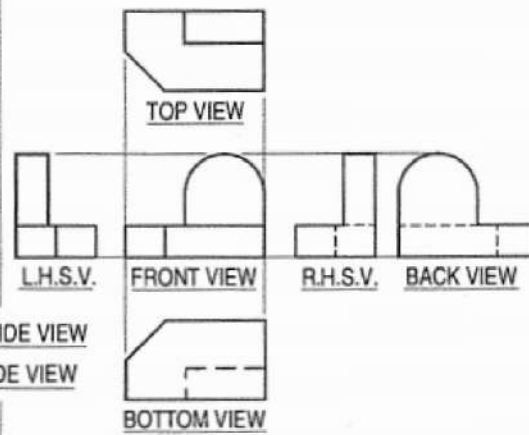

THIRD ANGLE PROJECTION





1

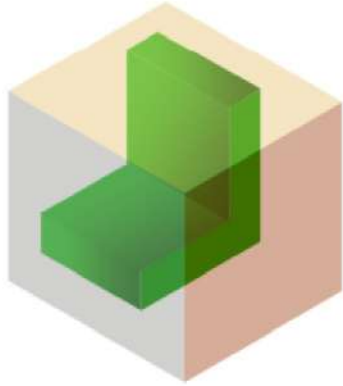

2

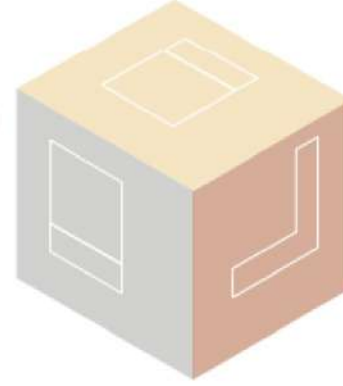

3

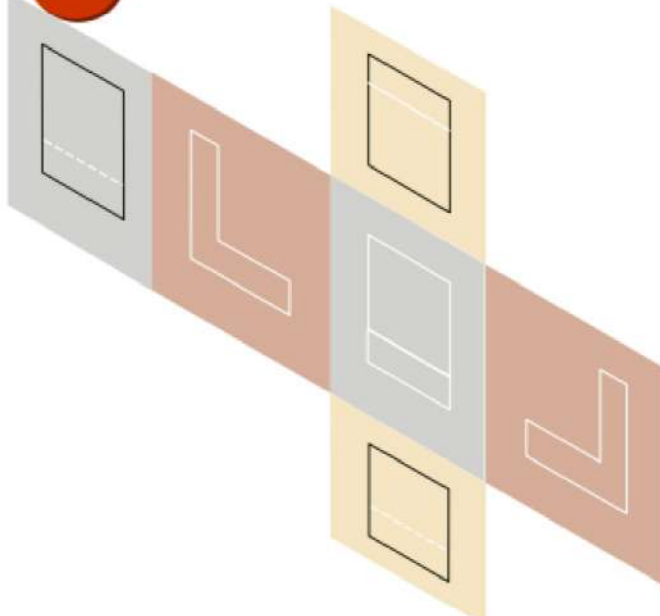

4

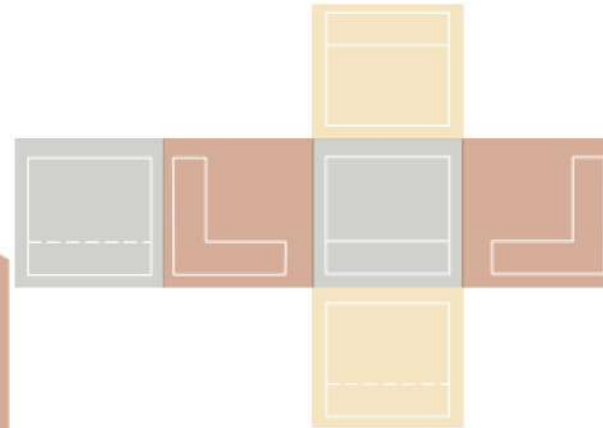

# Orthographic Projection

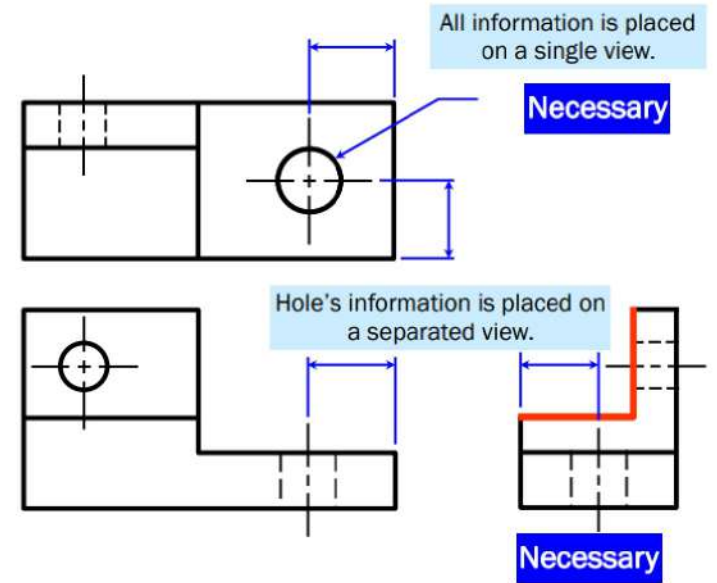
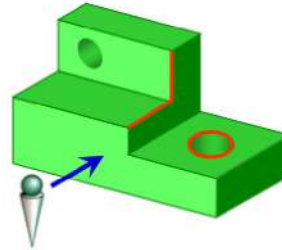
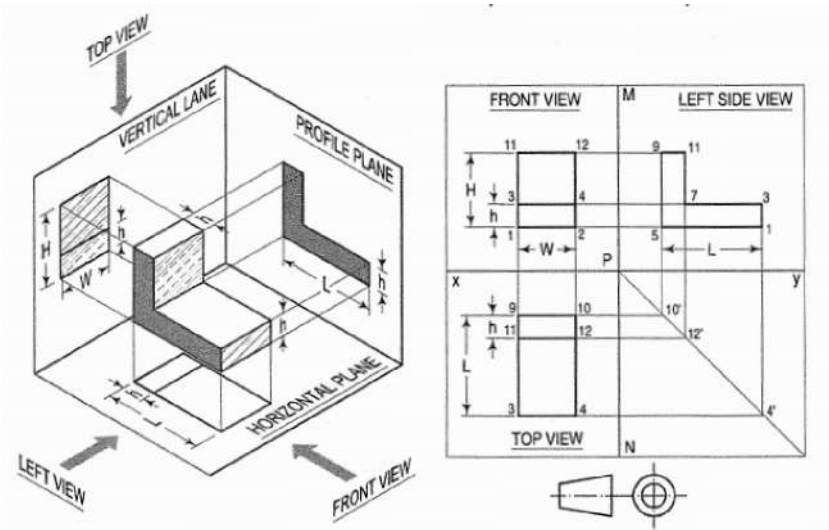



## Example-2

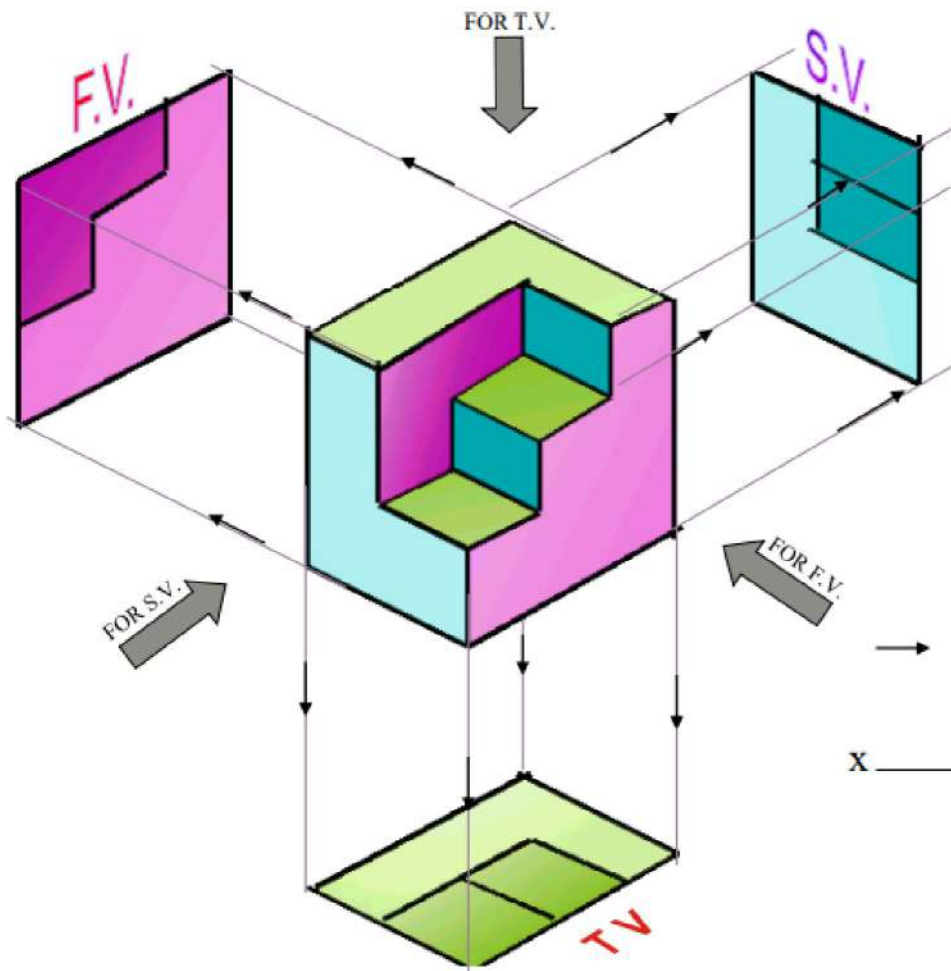

### ORTHOGRAPHIC PROJECTIONS

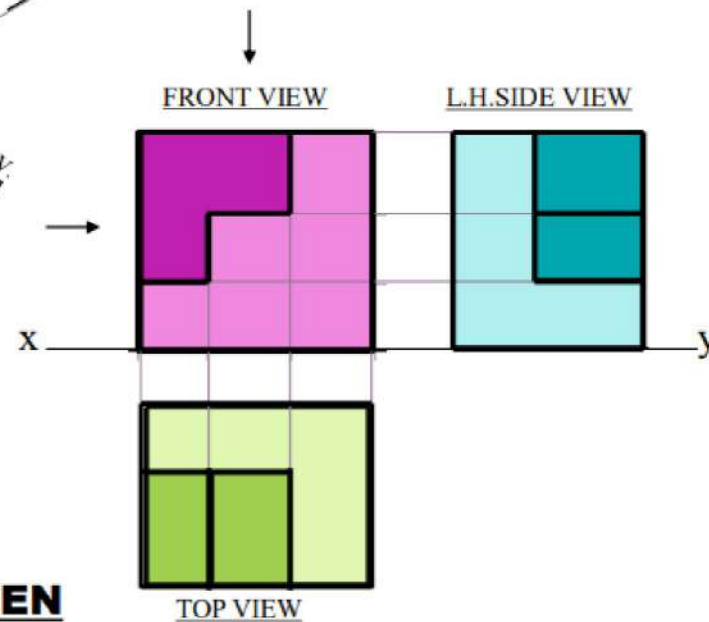

**PICTORIAL PRESENTATION IS GIVEN**  
**DRAW THREE VIEWS OF THIS OBJECT**  
**BY FIRST ANGLE PROJECTION METHOD**

